

LEADER FOX



Electric Bicycle Operating Instructions

Under the law, the dealer is obliged to attach the LEADER FOX Electric Bicycle Operating Instructions to every product



E – BIKE POWER RIDE

Urby



Introduction

Dear users,

Please read carefully all the information regarding your E-LF product to ensure optimal functioning of your e-bike. The following text containing a comprehensive description will provide you with information on all aspects and details (including installation, setting up and general use of the display) regarding the use of our display. This instruction document will also help you solve potential problems and failures.

What is an electric bicycle?

Electric bicycle is a conventional bicycle with an electric drive added to assist the rider. The motor function is actuated by pedalling, which is scanned by a special sensor installed in the pedal hub. Therefore, you have to keep pedalling on an e-bike, the motor is there only to help you. You can set an electric bicycle in motion also using a control button or an accelerator but only up to the maximum permitted speed of 6 KMPH (e.g. for walk assistance). The maximum speed of an e-bike with motor assistance is 25 KMPH, with a 10% tolerance (when this speed limit is reached, the motor switches off and you need to pedal just like with a regular bicycle). When your battery runs out of power or your motor is off, you can ride your electric bicycle as a conventional bike, without any resistance at all.

From the point of view of the Road Traffic Act, an electric bicycle whose features conform to European standard EN 15194-1 is regarded as a regular bicycle, i.e. you can ride on bike trails, do not need a driver's license and a helmet is mandatory only up to 18 years of age.

Description



Factors influencing the electric bicycle range

- 1. Rolling resistance of the tyres.** Leader Fox e-bikes are fitted with tyres with low rolling resistance and increased resistance to puncture. It is also important that the tyres are inflated properly. Therefore, if the tyres of your electric bicycle are underinflated, the range will decrease.
- 2. Weight of the electric bicycle.** The lower weight of the electric bicycle, the greater the range.
- 3. Battery status.** It depends on whether the battery was fully charged before your trip. It is also to be expected that the higher the number of discharge cycles the battery has undergone, the smaller capacity it has.
- 4. Profile and surface of the track.** The higher the elevation difference and the steeper hills you negotiate and the worse surface, the shorter the range.
- 5. Riding mode.** It depends on which of the three riding modes you have set.
- 6. Continuity of riding.** The more braking and acceleration, the shorter the range.
- 7. Air resistance.** For example, it depends on whether we ride a bicycle with low frame and sitting upright or whether we ride sporty bicycle with seat set to the same height as the handlebars.
- 8. Wind strength.** The stronger the wind we have back, the longer the range and vice versa.
- 9. Weight of the rider and load.** The greater the weight, the shorter the range.
- 10. External temperature.** The lower the temperature, the less battery capacity can be used while riding.

Electric set

M420

The system uses monitoring of torque, monitoring of speed of the pedal assist system and monitoring of real speed of wheels.

The system uses a dual protection feedback for measuring the speed signal to ensure safety and reliability of the system.

It has high starting torque, maximum torque of over 80 Nm, suitable especially for riding uphill.

It is highly efficient with low power consumption, long range, low noise levels, and smooth operation.

Description and scope of operation:

The motor unit works properly under the following operating conditions:

Temperature range - 20 + 45°C

Relative humidity - 15 – 95% RH

Maximum torque - ≥ 80

Weight - 3.6Kg

Noise - <55 dB

Dustproof/ waterproof -IP66

Certified -CE ROHS/ EN14766/ EN114764/ REACH

Front and rear light -DC 400mA/6V

Description of the power unit is placed on the cover and shows the following information:

MM G332.250 – -name of motor unit

1401 -date of manufacture e.g.: January 2014 in this case

0001 -is so-called serial number which ranges between 0000 and 9999, 0001 is for example the serial number

of the first manufactured motor.

36V -nominal voltage

250W -nominal motor power

Dimensions of the power unit:

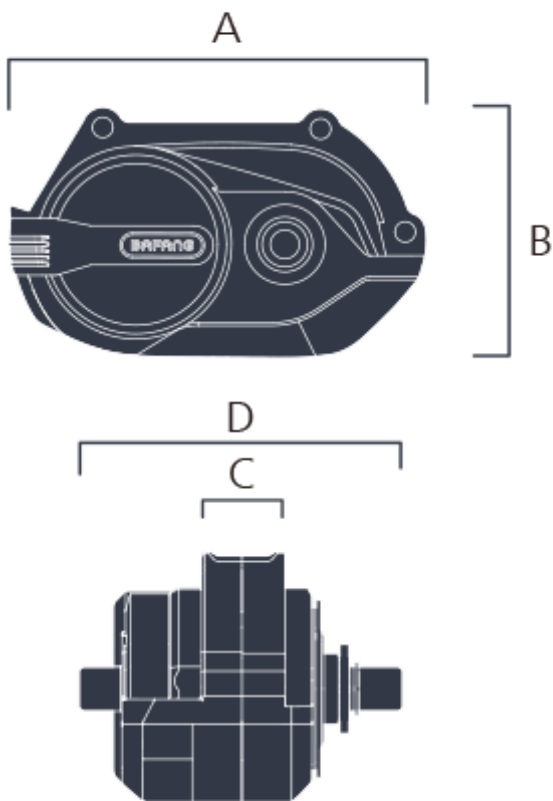

Dimension A	202 mm
Dimension B	123 mm
Dimension C	41.5 mm
Dimension D	154.8 mm

Safety instruction

Battery:

- Do not throw the battery into fire.
- Do not throw the battery into water.
- Do not use the battery for other appliances. It has been made specifically for this model.
- Do not dismantle or modify the battery.
- Do not connect the positive and negative poles of the battery.

Charger:

- Do not dismantle or modify the charger.
- Do not use the charger for other appliances. It has been made specifically for this model.
- Do not throw the charger into fire or water.
- Do not touch the charger with wet hands.
- Keep the charger from animals or children.
- Do not cover the charger.
- Do not use the charger if it is broken.

Charging set



Battery

Battery charging and maintenance:

Charge the battery in a dry environment to avoid short-circuit damage.

Charge the battery to at least 60% of the capacity once every 3 months even when the bicycle is not used.

Do not cover the battery or the charger.

Do not leave the battery constantly connected to the power source.

Do not use the battery for other appliances. It has been made specifically for this model.

Do not disassemble or modify the battery pack.

Do not throw the battery into fire or expose it to extreme temperatures.

Recharging time from zero to 100% is 1-7 hours.

Drive warranty:

The warranty applies to those drive parts that are not sensitive to improper handling (pack, electronics, charger, etc.); such parts are covered by a 24-month warranty.

The warranty does not apply to chemical parts of the battery and to capacity reduction due to normal use (39% after the expiry of two years); those parts are covered by a 12-month warranty.

Charging:

The battery is the most expensive part of an electric bicycle; therefore, pay increased attention during handling, charging and storage. The battery is sensitive to precise charging. Therefore, it is necessary to charge Li-Ion rechargeable batteries using only a charger supplied by us. Connect the charger to 220-240 V power outlet. 5A protected circuit is sufficient. The charger will automatically suspend charging when full capacity of all cells is reached.

We recommend discharging the battery in full after each ride to ensure that your battery will be up to its full capacity for your next ride. Charging the battery may last 1 to 5 hours depending on the condition of the battery cells. Charge it exclusively in covered dry areas (moisture and dripping water can damage the charger) at a temperature of 5 to 40°C.

The charging process is indicated by a red glowing LED. It will turn green when the battery is charged and the charging process is complete. The battery contains a charge-monitoring indicator (when the charge indicator button is pressed, the light indicator will come on). Always switch off the battery when finished riding the bike.

Normal battery behaviour:

If the motor stops running smoothly and switches to intermittent operation, it could be a sign of low battery capacity. In that case switch off the electric drive system and continue without motor assistance, as if riding a conventional bicycle.

Battery warming is normal and does not indicate any defect. The battery is protected by a temperature sensor and switches off automatically in case of excessive overheating. Wait until the battery cools down to its normal operating temperature and then ride on.

If you feel your total battery capacity has dropped, it could be caused by charging or operation in suboptimal climatic conditions. Carry out 3 full charging cycles. Fully discharge the battery while riding and then charge to its full capacity at room temperature.

If the charge indicator shows that the battery is discharged, there is still a minimum voltage level in it which protects it against damage but is not enough to power the electric bicycle. Recharge the battery as soon as possible. Never leave the battery fully discharged, it could result in its damage.

In the case, that the battery will be turned on more than 30 min and bike will not be used, the battery will be automatically switched off.

Proper care of the battery prolongs its life.

7 USER MANUAL FOR DP C080.CB



CONTENT

7.2 Introduction Of Display	2	7.7.1 "Imperial" / "Metric".....	8
7.3 Product Description	3	7.7.2 Set the Automatic Shutdown Time.....	8
7.3.1 Specification.....	3	7.7.3 Set the Backlight.....	9
7.3.2 Functional Overview.....	3	7.7.4 Set the Light Sensitivity.....	9
7.4 Display	4	7.7.5 Reset the Trip.....	9
7.5 Key Definition	4	7.7.6 Maintenance Prompt.....	10
7.6 Normal Operation	5	7.7.7 View the Wheel Size & Speed Limit.....	10
7.6.1 Power ON/OFF.....	5	7.7.8 View the Battery Info.....	10
7.6.2 Select the Power-Assisted Mode.....	5	7.7.9 View the HMI Info.....	11
7.6.3 View the Data.....	6	7.7.10 View the Controller Info.....	11
7.6.4 Adjust the Headlight/backlight.....	6	7.7.11 View the Sensor Info.....	11
7.6.5 Walk Assistance.....	6	7.7.12 Set the UI Theme.....	11
7.6.6 Type-C Charge.....	6	7.7.13 View Historical Error Codes.....	12
7.6.7 Bluetooth Function.....	7	7.8 Error Code Definition	13
7.7 Settings	8		

7.1 IMPORTANT NOTICE

- If the error information from the display cannot be corrected according to the instructions, please contact your retailer.
- The product is designed to be waterproof. It is highly recommended to avoid submerging the display under water.
- Do not clean the display with a steam jet, high-pressure cleaner or water hose.
- Please use this product with care.
- Do not use thinners or other solvents to clean the display. Such substances can damage the surfaces.
- Warranty is not included due to wear and normal use and aging.
- Any changes or modifications not expressly approved by the party responsible for compliance could void the user's authority to operate the equipment.
- This device complies with part 15 of the FCC Rules. Operation is subject to the following two conditions: (1) This device may not cause harmful interference, and (2) this device must accept any interference received, including interference that may cause undesired operation.
- This equipment has been tested and found to comply with the limits for a Class B digital device, pursuant to Part 15 of the FCC Rules. These limits are designed to provide reasonable protection against harmful interference in a residential installation. This equipment generates uses and can radiate radio frequency energy and, if not installed and used in accordance with the instructions, may cause harmful interference to radio communications. However, there is no guarantee that interference will not occur in a particular installation. If this equipment does cause harmful interference to radio or television reception, which can be determined by turning the equipment off and on, the user is encouraged to try to correct the interference by one of the following measures: (1) Reorient or relocate the receiving antenna. (2) Increase the separation between the equipment and receiver.(3) Connect the equipment into an outlet on a circuit different from that to which the receiver is connected.(4) Consult the dealer or an experienced radio/TV technician for help.

7.2 INTRODUCTION OF DISPLAY



- Model: DP C080.CB
- The housing is made of PC/ABS and the LCD screen is made of aluminosilicate glass.

- The label marking is as follows:

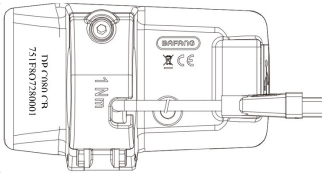

7.3 PRODUCT DESCRIPTION

7.3.1 Specification

- LCD screen
- Power supply: 36/48/52Vdc
- Operating temperature: -20 °C~45 °C
- Storage temperature: -20 °C~60 °C
- Waterproof: IPX7
- Storage Humidity: 30%-70% RH

7.3.2 Functional Overview

- CAN communication protocol; Easy and user-friendly operation with three keys.
- Speed indication: including real-time speed, maximum speed "MAX" and average speed "AVG".
- Km/mile shift
- Smart power indication: Provides stable battery percentage alerts through optimized algorithms.
- Automatic control of light-sensing headlight
- Backlight brightness 4-level adjustment
- Gear control: 6 modes in total
- Mileage indication: The maximum mileage can be displayed up to 99999. Single mileage can be shown as TRIP; accumulated mileage can be shown as ODO.
- Smart indication: remaining mileage can be shown as RANGE, energy consumed can be shown as Cal (calories).
- Error code indication.
- Walk assistance.
- Type-C charging
- Maintenance prompt.
- Bluetooth.
- 6 languages: English, German, Dutch, French, Italian, Czech.

7.4 DISPLAY

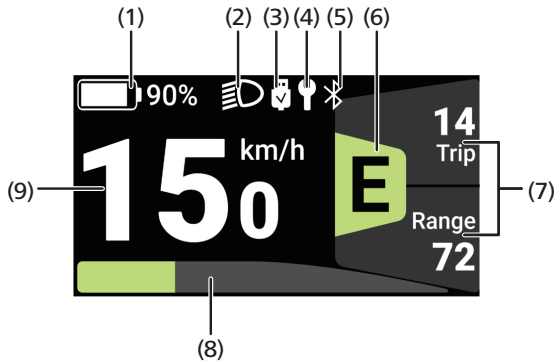

- 1 Battery capacity
- 2 Headlight
- 3 Charge
- 4 Maintenance
- 5 Bluetooth
- 6 Power-assisted mode
- 7 Multifunction indication
- 8 Watt
- 9 Real-time speed

7.5 KEY DEFINITION



- 1 "+" / Headlight key
- 2 "Power" key
- 3 "-" / Walk assistance key

7.6 NORMAL OPERATION

7.6.1 Power ON/OFF

Power ON: Press and hold "⏻" (≥ 2s) when the HMI is OFF.

Power OFF: Press and hold "⏻" (≥ 2s) when the HMI is ON to power OFF the HMI.



7.6.2 Select the Power-Assisted Mode

press "+" or "-" to switch the power-assisted mode and change the power of the motor.

The lowest gear is E, and the highest gear is B (user selectable).

The default mode is E; 0 means the e-bike is in neutral position.

E (Eco):	Green	ECO mode
T (Tour):	Blue	TOUR mode
S (Sport):	Indigo	SPORT mode
S+ (Sport+):	Orange	SPORT+ mode
B (Boost):	Purple	BOOST mode

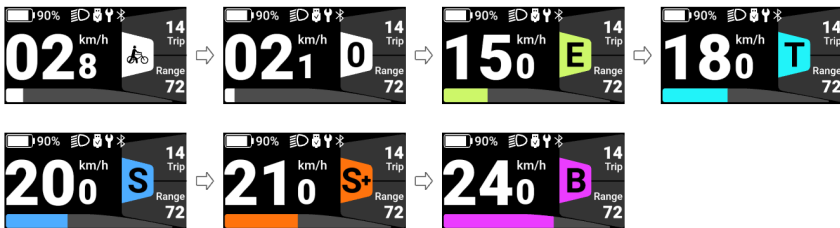

7.6.3 View the Data

In the main interface, press the "⏻" to enter the interface. Press the "⏻" to switch data displays.

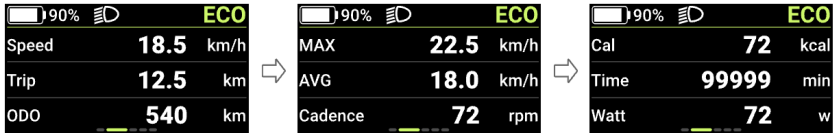

7.6.4 Adjust the Headlight/backlight

Press and hold ($\geq 2s$) "+" to turn on the headlight, the backlight luminance of the HMI will decrease, and the light icon appears. Press and hold the "+" again to turn off the headlight, the HMI backlight luminance will increase, and the light icon will disappear.

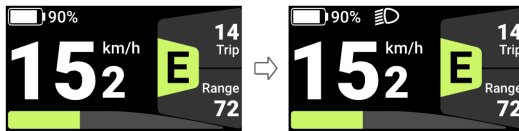

7.6.5 Walk Assistance

When the system not in operation, press the "-" to shift to 0, and then press the "-" again, and the symbol "🚲" will appear and be normally on.

Press and hold the "-", the symbol "🚲" will flash (frequency 500ms), and the e-bike will go into walk assistance mode (If no speed signal is detected, the HMI will display a speed of 2.5 km/h).

Release the "-" to exit from the walk assistance mode, and the symbol "🚲" will stop flashing and be will normally on. If no operation within 5s, the mode will be automatically switched to 0.

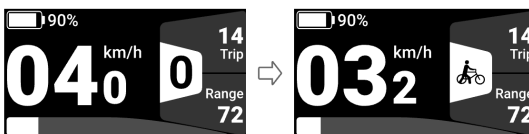

7.6.6 Type-C Charge

To charge the HMI, connect the Type-C cable with the HMI. If the HMI is OFF, connect the Type-C cable with the HMI and power ON the HMI. Maximum charging voltage is 5V; maximum charging current is 500 mA.

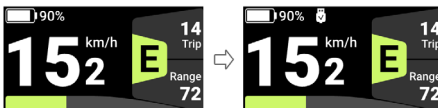

7.6.7 Bluetooth Function

The HMI can be connected to Bafang Go App through Bluetooth.

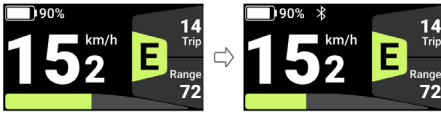

Scan the QR code in the figure below to install the App.



(BAFANG GO for Android™ and IOS™)

The data that can be sent to the APP are as follows:

No.	Function
1	Speed
2	SOC
3	Power-assisted modes
4	Battery info
5	Sensor signal
6	Remaining mileage
7	Calories
8	System component information
9	Current
10	Current power-assisted mode
11	Trip
12	ODO
13	Headlight state
14	Error code

7.7 SETTINGS

Press and hold the "+" and "-" simultaneously to enter "Setting". Press "+" or "-" to select "HMI Setting", "Information", "Themes", "Language" or "EXIT," and press "⏻" to enter.

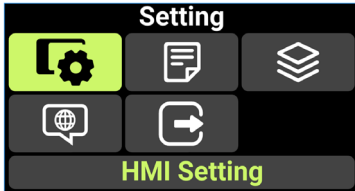

7.7.1 "Imperial" / "Metric"

Enter the "Setting", press "+" or "-" to select "Unit". Press "⏻" to enter the setting, press "+" or "-" to select "Metric"/"Imperial", and press "⏻" to save and return to "Unit." To save and return to the main interface, press and hold "+" and "-" simultaneously, or press "BACK" → "EXIT".

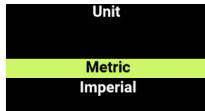
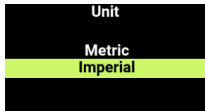

7.7.2 Set the Automatic Shutdown Time

Enter the "Setting", press "+" or "-" to select "Auto Off". Press "⏻" to enter the setting, press "+" or "-" to select "OFF" / "1 Min" / "2 Min" / "3 Min" / "4 Min" / "5 Min" / "6 Min" / "7 Min" / "8 Min" / "9 Min" / "10 Min", and press the "⏻" to save and return to "Auto Off". To save and return to the main interface, press and hold "+" and "-" simultaneously, or press "BACK" → "EXIT". "OFF" means to cancel the automatic shutdown function.

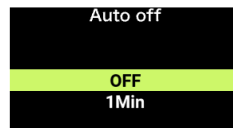
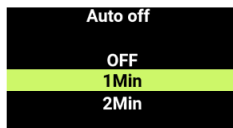

7.7.3 Set the Backlight

Enter the "Setting", press "+" or "-" to select "Brightness". Press "⏻" to enter the setting, "+" or "-" to select "100%"/"75%"/"50%"/"25%", and press "⏻" to save and return to "Brightness". To save and return to the main interface, press and hold "+" and "-" simultaneously, or press "BACK"



7.7.4 Set the Light Sensitivity

Enter the "Setting", press "+" or "-" to select "AL sensitivity". Press "⏻" to enter the setting, press "+" or "-" to adjust the light sensitivity, "OFF"/"1"/"2"/"3"/"4"/"5". "OFF" means to turn off the function. The numbers 1 through 5 correspond to different levels of light sensitivity, from weak to strong. Press "⏻" to save and return to "AL sensitivity". To save and return to the main interface, press and hold "+" and "-" simultaneously, or press "BACK" → "EXIT".



7.7.5 Reset the Trip

Enter the "Setting", press "+" or "-" to select "Trip reset". Press "Power button" to enter the setting, press "+" or "-" to select "NO"/"YES" ("YES" means to clear, "NO" means not to clear), and press the power button to save and return to "Trip reset". To save and return to the main interface, press and hold "+" and "-" simultaneously, or press "BACK" → "EXIT".



7.7.6 Maintenance Prompt

Enter the "Setting", press "+" or "-" to select "Service". Press "⏻" to enter the setting, press "+" or "-" to select "OFF"/"ON" ("OFF" means to turn off the function; "ON" means to turn on the function). Press "⏻" to save and return to "Service". To save and return to the main interface, press and hold "+ and -" simultaneously, or press "BACK" → "EXIT". (Note: The maintenance prompt function is turned off by default. When it is turned on and the ODO of the e-bike exceeds 5,000 km, "🔋" will appear on the HMI.)



7.7.7 View the Wheel Size & Speed Limit

Enter the "Information", select "Controller Info", and press the "⏻" to enter. Select the "→" icon, and press the "⏻" to enter to view the "Wheel Size" and "Speed Limit" information. To save and return to the main interface, press and hold "+ and -" simultaneously, or press "BACK" → "EXIT".

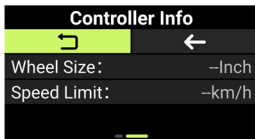

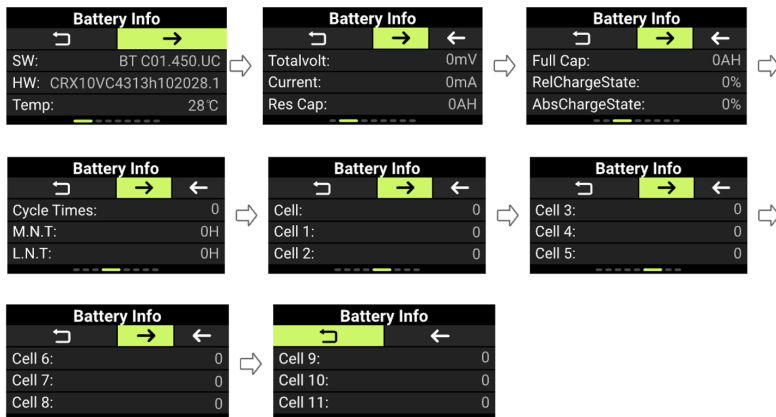

7.7.8 View the Battery Info

Enter the "Information", press "+" or "-" to select "Battery Info". Press "⏻" to enter. Press "⏻" to view the battery information. Select "↔", and press "⏻" to return to "Battery Info". To save and return to the main interface, press and hold "+ and -" simultaneously, or press "BACK" → "EXIT".



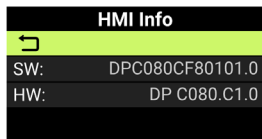

7.7.9 View the HMI Info

Enter the "Information", press "+" or "-" to select "HMI Info". Press  to enter. The sequence is "SW: → HW:". Press  to return to "HMI Info". To return to the main interface, press and hold "+" and "-" simultaneously, or press "BACK" → "EXIT".



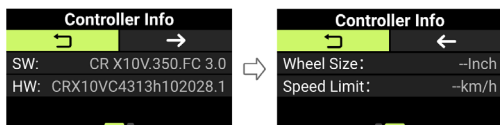

7.7.10 View the Controller Info

Enter the "Information", press "+" or "-" to select "Controller Info". Press  to enter and press "+". The sequence is "SW: → HW:". Press  to return to "Controller Info". To return to the main interface, press and hold "+" and "-" simultaneously, or press "BACK" → "EXIT".



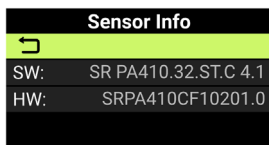

7.7.11 View the Sensor Info

Enter the "Information", press "+" or "-" to select "Sensor Info". Press  to enter. The sequence is "SW: → HW:". Press  to return to "Sensor Info". To return to the main interface, press and hold "+" and "-" simultaneously, or press "BACK" → "EXIT".



7.7.12 Set the UI Theme

Enter the "Setting", press "+" or "-" to select "Themes". Press  to enter it. Press "+" or "-" to select the UI theme you want. Press  to save and the HMI will be reset and restarted. If you do not want to change the theme, press and hold "+" and "-" simultaneously to exit to the main

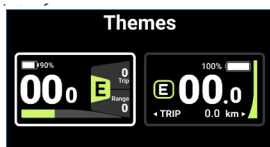

7.7.13 View Historical Error Codes

Enter the "Information", press "+" or "-" to select "Error Code". Press "⏻" to enter and press "+" to view the last 10 error messages, "E-Code1" to "E-Code10". Press "⏻" to return to "Information", or press and hold "+" and "-" simultaneously to return to the main interface.

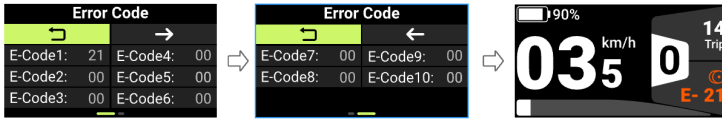

7.8 ERROR CODE DEFINITION



The HMI can show the faults of Pedelec. When a fault is detected, one of the following error codes will be indicated too.

Note: Please read carefully the description of the error code. When the error code appears, please first restart the system. If the problem still persists, please contact your dealer or technical personnel.

See Appendix B for the detailed error code list.

Electric set warranty

Complaint procedure:

Submit any complaints concerning the electric set or the battery to your dealer.

When filing a complaint, submit a proof of purchase and a warranty certificate with the registered serial number of the battery and indicate the reason for the complaint and a description of the defect.

Warranty conditions:

24 months for electric bicycle components – applies to manufacturing and material defects beyond normal wear and tear caused by use.

12 months for battery life – the nominal battery capacity does not drop below 70% of the total capacity over 12 months from the sale of the electric bicycle.

Warranty conditions:

The electric set must be used exclusively for the purposes it is intended for.

The electric set must be used, stored and maintained in accordance with these Operating Instructions.

A warranty claim shall expire:

If it is found out that the damage to the product is due to the user's fault (accident, inexpert handling beyond the framework of these Operating Instructions, tampering with the structure of the electric bicycle or connection of the electric system, improper storage, etc.).

Expiry of the warranty period.

The warranty only applies to the first owner

Warning

If you do not understand any of the points in these Operating Instructions, please contact the dealer for explanation. Please read the whole manual!

Do not lend the e-bike to persons not briefed in its use and operation. Complaints resulting from improper handling will not be accepted.

The LF Energy electric bicycle is not intended for use by children under 15 years of age. Likewise, the electric bicycle cannot be used by persons unable to pedal or handle it independently. The manufacturer is not to be held responsible for any potential injuries or damage to the bicycle!

Ideal weather conditions for using an electric bicycle are dry days, when the outdoor temperature is above 10°C. When used at lower temperatures, the battery discharges faster due to physical phenomena. Using the electric bicycle at temperatures below 0°C is not recommended.

Do not expose the bicycle to direct sunlight as it is fitted with a protective temperature sensor for the electric motor.

Never submerge the battery, the charger and other electric components in water or another liquid.

Never wash the electric bicycle in a pressure washer (WAP) and always remove the battery before washing

It is forbidden to tamper with the connections of the electric motor, the control unit and the battery. Violating this section may result in the warranty not being acknowledged or in irreversible damage to the electric bicycle.

DO NOT USE chargers and components other than the ones included with the electric bicycle.

We cannot be held responsible for damage caused by use of other non-approved goods

WARNING:

The product is not intended for extreme riding styles, such as jumping, riding off curbs or stairs, or any other excessive loading of the bicycle. It is also not suitable for use in demanding terrain. Using the product contrary to its intended purpose may lead to damage and to the loss of the right to claim defects caused by improper use.

LEADER FOX



Enjoy many pleasant and safe kilometres on your new electric bicycle.

Your Leader Fox Team



**Czech brand of electric bicycles.
BOHEMIA BIKE**

Address

Pujmanové 1753/10 a
140 00 Praha 4 – Nusle

Development, design and manufacturing

Okružní 697
České Budějovice 37001

Phone: 388 314 885
Email: info@leaderfox.cz

